

#3

Poured-in-place Concrete Residential Construction: Moisture Management Strategies

BUILDER INSIGHT

BUILDER INSIGHT is a series of bulletins designed to provide practical information on new technologies, research results, good building practices and emerging technical issues in residential construction to Licensed Residential Builders and others in the industry.



Homeowner
Protection Office
Branch of BC Housing

Overview

Poured-in-place concrete construction has become an increasingly popular form of construction for mid and high-rise residential buildings in British Columbia. Poured-in-place concrete walls are cost effective since they combine the functions of a structural element and an exterior wall assembly. Concrete also provides great flexibility and simplicity in building design.

While offering many advantages from a design and construction perspective, poured-in-place concrete construction also brings challenges. Compared with buildings constructed in the past, today's poured-in-place concrete buildings are more complex in terms of building form and interface details. In addition, today's buildings place a greater emphasis on air tightness and mechanical ventilation. These new complexities mean that close attention needs to be paid to moisture management strategies to avoid both rainwater penetration and interior moisture caused by condensation. This bulletin highlights various strategies and steps that can be taken to facilitate continued effective design and construction practices for exposed poured-in-place concrete walls.

Rain Penetration Control: A Priority Performance Objective

The success of a poured-in-place concrete wall clearly involves achieving many performance objectives. The control of heat, air and moisture flows (both vapour and rain) are important, and the wall assembly

continued on next page

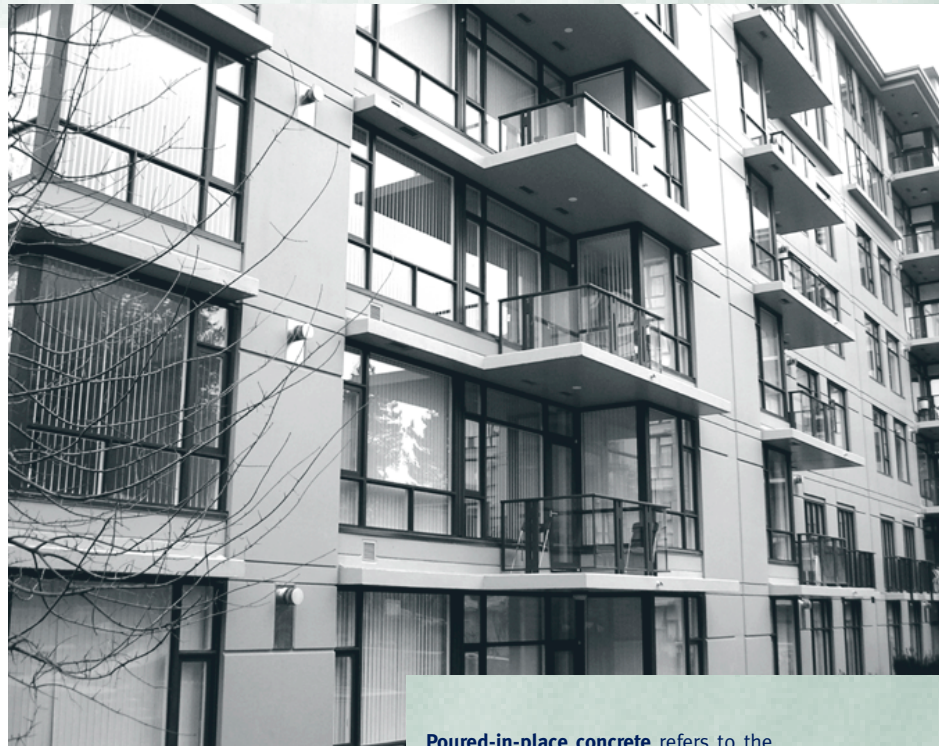

This bulletin is published by the Homeowner Protection Office (HPO), a branch of BC Housing, and prepared by RDH Building Engineering Limited. It is based on the **Study of Poured-in-place Concrete Wall Assemblies in Coastal British Columbia** funded by the HPO and Canada Mortgage and Housing Corporation (CMHC). See *For More Information* at the end of this bulletin on how to obtain a copy of this study, and for further references on this topic.



Poured-in-place concrete refers to the concrete elements of the building (walls, columns and floor slabs) that are formed, placed and cured in their intended final location at the building. They are distinct from pre-cast concrete elements that are formed, placed and cured elsewhere on the site, or off-site, and then relocated to their final in-service position at the building.

(Photo reproduced with permission from Polygon Homes Ltd.)



Building Form

Balconies and eyebrow projections provide protection to walls below and reduce wetting.

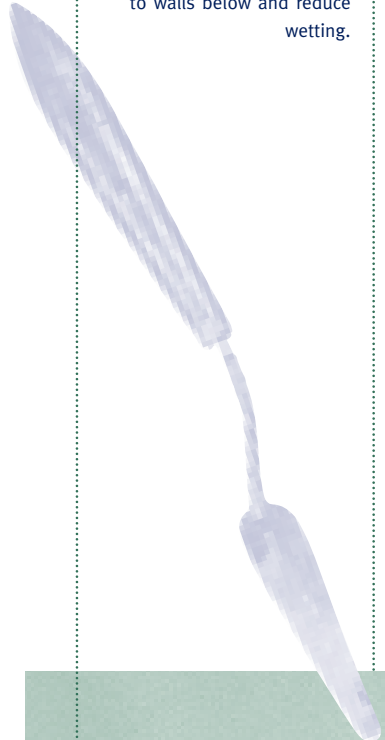

must also be durable, constructible and maintainable.

Rain penetration control should be considered a priority performance criterion. Achieving this objective is not easy, particularly in the B.C. coastal climate. Many of the other objectives can be achieved in a variety of ways, and relatively easily, once the rain penetration control strategy is defined.

Building form has a profound impact on the risk of water penetration since building form impacts the amount of wetting that can occur on a wall, as well as the extent to which problematic details occur. Choices made with respect to building form determine how dependent rain penetration control performance is on the quality of the design and construction of details. Building form that minimizes the potential for cracking, wetting and the extent of uncompressed construction joints provides lower risk (Source: CMHC).

Two Lines of Water Penetration Resistance

Poured-in-place concrete walls by their nature provide two lines of resistance very differently than rainscreen walls. The first line of water penetration resistance for a concrete wall is the face of the concrete, which is usually made more water resistant through the use of a coating. The second line of resistance is created by the concrete itself, since it has sufficient thickness and mass to restrict the inward movement of water. Some moisture can be absorbed into the concrete and later dry to the exterior as weather conditions permit. For portions of the poured-in-place concrete wall area that are free of cracks and joints, the key variables for effective water penetration control are, therefore, the properties of the coating applied to the concrete and the water resistive characteristics of the concrete material.

The real challenge with respect to water penetration control for

poured-in-place concrete walls is in achieving a second line of resistance at cracks, penetrations, construction joints and control joints in the concrete. At these locations the coating will not bridge any significant cracks in a durable manner. Cracks or joints essentially represent a hole through the concrete. Gravity, pressure gradients created by the wind and capillary forces can all act to drive water through these holes to the building interior (Source: CMHC).

Sources of Water Penetration

Cracks at unanticipated locations, construction joints and control joints are the most common sources of water penetration through structural concrete walls. Design considerations for joints include:

- design of building form to limit the horizontal length of concrete walls, thereby limiting the need for control joints
- building form and geometry to prevent the initiation of cracks. For example, re-entrant corners and similar discontinuities should be avoided, and
- spacing of control joints to minimize shrinkage and cracking between the joints.

Appropriate detailing is required to prevent migration of water through construction joints and control joints. This detailing includes the use of waterstops and other joint sealants to provide two layers of resistance to water leakage.

Form tie holes, pipe runs and honey-combed concrete are also common locations of water movement through concrete. These should be filled with crystalline grout from the interior and hydraulic cement from the exterior. All cracks that appear and are greater than hairline in thickness should be routed and sealed like construction joints, if they are subject to ongoing movement. The cracks should be routed and sealed with crystalline grout installed from the interior, if they are static. Other potential crack mitigation measures include injection with urethane or epoxy.

Test for Water Tightness

Testing of the concrete wall for water tightness is relatively easy to undertake during construction. Simply wetting the

Construction Joint refers to the contact area between previously placed concrete, against or upon which new concrete is to adhere. The previously placed concrete has become rigid enough so that the new concrete cannot be incorporated integrally by vibration with the placed concrete.

Control Joint is an intentional joint positioned in concrete to encourage cracking due to shrinkage at a specific location.

(SOURCE: CMHC)

wall for several hours from the exterior (pressure differential not usually required) will provide an indicator of the water tightness performance. This type of testing should be undertaken prior to closing in the walls on the interior so that locations of leaks can be readily identified and addressed. The windows should be installed prior to the testing. However, the exterior sealants and coatings are optional, recognizing that if sealants and coatings are not in place, the test is more severe because it is being applied to a single line of defence. The results from the concrete testing should be correlated with the results of the in-situ pressurized window and window interface testing.

Other Heat, Air and Moisture Control Functions

Primary air tightness is readily achieved in poured-in-place concrete walls by the concrete itself and by continuity of air tightness at joints, penetrations and interfaces. Hygrothermal modeling of these wall assemblies indicates that vapour diffusion control is important both for inward and outward acting vapour drives. The modeling shows that walls incorporating a layer of polystyrene insulation (XPS) or spray-in-place polyurethane foam immediately adjacent to the inside surface of the concrete will have the least overall risk for condensation moisture problems related to vapour diffusion, air movement and thermal bridging. Not only does this insulation layer provide an effective balance for in-

ward and outward acting vapour drives, it also eliminates the potential for air-leakage-related condensation (interior air movement into a space created between the concrete and the internal stud wall) and provides a relatively continuous thermal insulation layer within the wall to reduce the impact of the highly conductive steel studs (Source: CMHC).

The overall thermal resistance provided by the insulating layers in poured-in-place concrete wall assemblies is reduced by thermal bridging caused by intersecting concrete walls and floor slabs, and possibly by steel studs. The effects of thermal bridging generally make poured-in-place concrete walls much less efficient than walls that are continuously insulated from the exterior (Source: CMHC).

It is clearly beneficial to detail penetration and interfaces within wall assemblies to ensure there are thermal breaks between the concrete and other thermally conductive building components, such as steel studs and window frames.

Critical Features and Details

Several features and details are critical in poured-in-place concrete buildings with respect to water penetration control. These include construction joints, control joints, planter curbs and parapets, window interface details and surface runoff control features. Examples of these features and details follow.

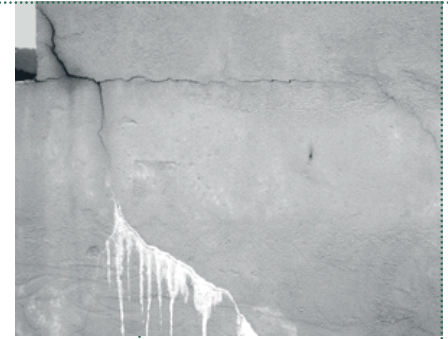

Water Penetration and Staining at Cracks

The lack of a cap on the upstand wall and the lack of a joint can result in cracking, water penetration and efflorescence.

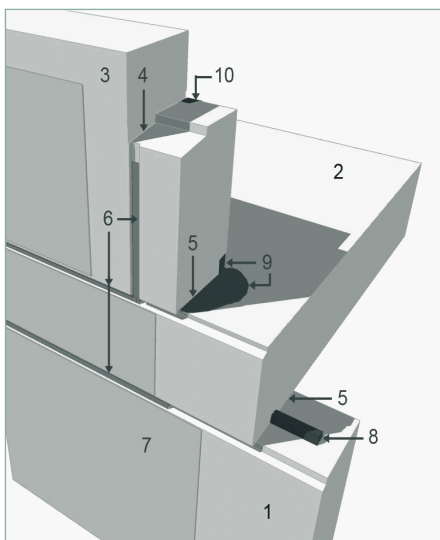

Construction and Control Joints

Two lines of defence must be provided at all construction and control joints. An example of how this can be achieved is shown in the adjacent figure.

1. Storage capability of concrete wall (second line of defence)
2. Concrete slab
3. Storage capability of concrete wall or column (second line of defence)
4. Vertical control joint created in a monolithic concrete pour of an up-stand wall under the window opening and the adjacent full height wall
5. Horizontal construction joint between walls and floor slab
6. Caulked joint in reglet at joints on exterior of concrete surfaces (first line of defence)
7. Coating on wall (first line of defence)
8. Bentonite strip at construction joint (second line of defence)
9. Crystalline drypack in reglet and crystalline slurry at construction joint (second line of defence)
10. Crystalline drypack in reglet at vertical control joint (second line of defence)

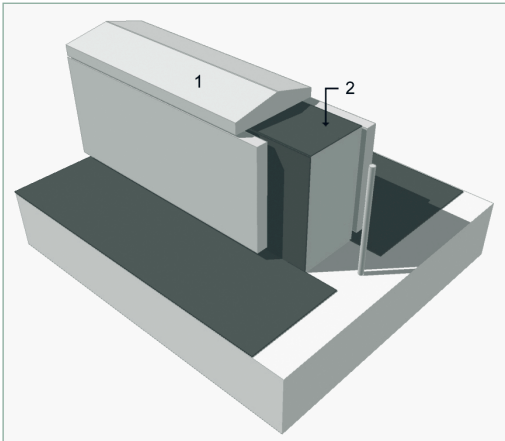

Planters, Curbs and Parapet Walls

Planters and curbs should be treated like a roof parapet. The waterproofing membrane should be carried up and over the top of the curb. Precast or cast-in-place concrete can be installed to provide an exposed concrete finish, and to protect the membrane. This should be done in a way that allows the membrane to be maintained and replaced.

Best Performance

1. Removable precast concrete protects the membrane and facilitates membrane maintenance and replacement
2. Membrane continuous up and over curb—no membrane terminations

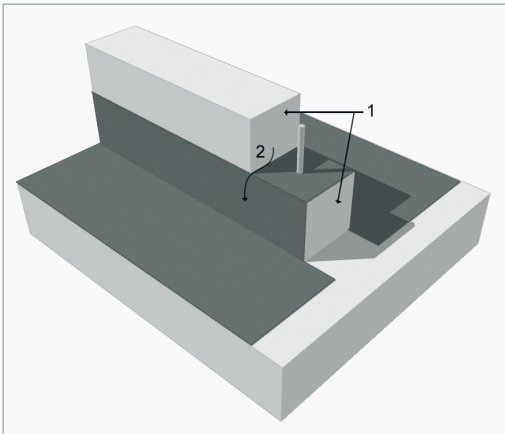

Good Compromise

1. Curb cast in two pours, with membrane continuous up and over lower curb
2. Water entering cracks in top curb flows to exterior

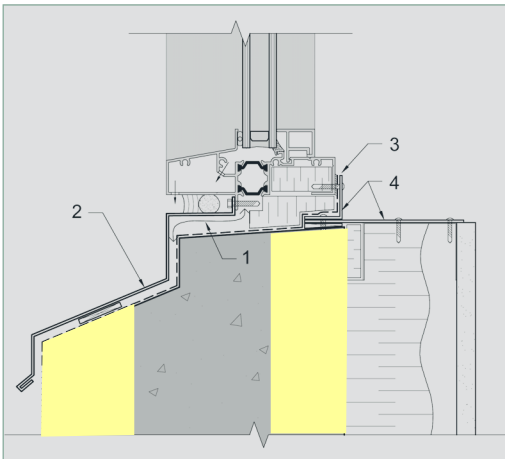

Window Interface

Continuity of barriers at interfaces is critical to successful performance. Key features of a good window sill detail include:

1. Sub-sill drainage provided
2. Exposed surface of concrete protected and waterproofed
3. Connection of window to membrane on metal angle, and the metal angle—sealant—concrete joint provides continuity of the air barrier and moisture barrier
4. Heat sink strap which connects studs to the support angle and transfers heat to the window to reduce condensation potential

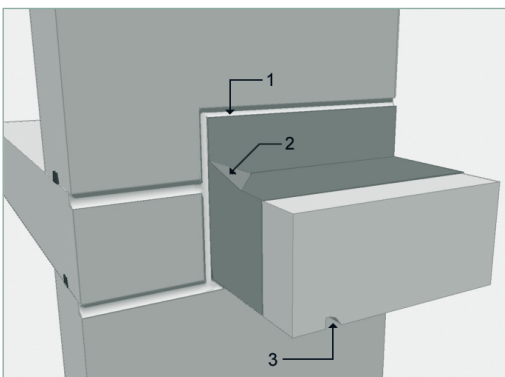

Surface Runoff Features

Avoiding concentrated runoff and having water drip free of the building face are good water management features:

1. Balcony membrane terminating in reglet to prevent water running over unprotected edge of membrane
2. Cant at wall to balcony interface to direct balcony runoff water away from wall
3. Drip edge on the under-side of the balcony slab so that water drips free of slab rather than running along underside

pooured-in-place

examples of features and details

Concrete Design

Manufacturers' documents and other documents provide guidance on the appropriate use of most of the materials used in poured-in-place concrete wall assemblies. The exception to this is the concrete itself,

where only general guidance is provided through existing standards. Control of the location and frequency of cracking and construction joints is the most important element for water penetration control. This requires the involvement of the architect, structural designer, contractor, concrete supplier and the building enclosure consultant. Mix design, rebar placement, waterstop selection and placement, and coating selection

require input from many different parties involved in the project and can have a significant impact on the overall water penetration resistance of the concrete.

Coating Selection

The most common method of reducing permeability of the surface of the concrete is through the addition of a coating. Since concrete, by its nature, is porous and minor amounts of moisture are anticipated to exist behind the face, the coating must be able to allow this moisture to dry back to the exterior when conditions permit (Source: CMHC). A wide range of performance characteristics must be considered in

Maintenance and Renewal Considerations

The maintenance and renewal plan should focus on provisions for inspection, cleaning, maintenance, repair and renewal of the coating and sealants.



selecting a coating. A summary of these considerations is provided in the table below.

Below Grade Concrete Elements

The exterior environmental conditions are quite different for below grade poured-in-place concrete elements and, therefore, requires a special application of this technology. The interior space may be occupied living space or unoccupied space such as a parking garage. The exterior side of the wall experiences more moderate temperature swings, but may be subjected to hydrostatic pressure.

Assuring performance of below grade poured-in-place concrete elements has some similarities and some very key differences to above grade poured-in-place concrete walls. For example, the requirements for concrete mix design, construction and control joint waterproofing, and crack control are generally the same for both types of walls. The key difference in strategy reflects the possible presence of hydrostatic pressure. Much more robust assemblies and details need to be used when hydrostatic pressure exists.

The table on page 6 presents examples of moisture control strategies that could be considered for below grade concrete elements.

Comparison of Coatings and Performance Characteristics

PROPERTY	ACRYLIC LATEX PAINT	ACRYLIC LATEX ELASTOMERIC	SILICONE ELASTOMERIC
Thickness (mil)	2-3	10-20	10
Crack Bridging	Poor	Good	Excellent
Elasticity	Poor	Good	Excellent
Recoats Before Complete Removal Required	5	2-3	5
Water Penetration Resistance	Poor	Good	Excellent
Vapour Permeability	Good	Poor	Excellent
Relative Cost	1	2	2.2
Life Expectancy (Years)	2-5	5	10
Abrasion Resistance	Good	Good	Poor to Good
Surface Preparation/Ease of Application	Easy	Easy	Difficult
UV Stability	Poor	Poor	Excellent
Ease of Cleaning (Source: CMHC)	Moderately Difficult	Moderately Difficult	Very Difficult

Maintenance and Renewals

The concrete, and the associated coating and sealant materials will require periodic maintenance and renewals work over the service life of the building. The maintenance and renewals plan should, therefore, focus on provisions for inspection, cleaning, maintenance, repair and renewal of the coating and sealants. Later in the service life of the walls it may be necessary to undertake more significant inspection and repair work such as sounding of the concrete surfaces, and repair to spalls or delaminations.

Examples of Below Grade Moisture Control Strategies

	Walls				Slab on Grade			
	EXTERIOR DRAINAGE	MOISTURE BARRIER	CONTROL/ CONSTRUCTION JOINTS	INTERIOR (INSIDE CONCRETE)	EXTERIOR DRAINAGE	MOISTURE BARRIER	CONTROL/ CONSTRUCTION JOINTS	INTERIOR
NO HYDROSTATIC PRESSURE UNOCCUPIED/ UNFINISHED	Yes	Dampproofing	Waterstops	Bare Concrete	Yes	Poly/HPDE	Unsealed	Bare Concrete
NO HYDROSTATIC PRESSURE OCCUPIED/ FINISHED	Yes	Waterproofing	Waterstops	Fungal Resistant Finishes	Yes	Waterproofing	Unsealed	High Humidity Resistant Finishes
HYDROSTATIC PRESSURE UNOCCUPIED/UNFINISHED LOW PERMEABLE SOILS (CLAY)	No	Waterproofing Fully Bonded to Concrete	Waterstops	Bare Concrete	Yes	Poly/HPDE	Unsealed	Bare Concrete
HYDROSTATIC PRESSURE OCCUPIED/FINISHED LOW PERMEABLE SOILS	No	Waterproofing Fully Bonded to Concrete	Waterstops	Drainage Layer+ Gutter and Drains, Vapour Barrier and Mold Resistant Finishes	Yes	Waterproofing	Waterstops	High Humidity Resistant Finishes
HYDROSTATIC PRESSURE UNOCCUPIED/UNFINISHED HIGH PERMEABLE SOILS (SAND)	No	Waterproofing Fully Bonded to Concrete	Waterstops	Bare Concrete	No	Waterproofing Fully Bonded to Concrete	Waterstops	Bare Concrete
HYDROSTATIC PRESSURE OCCUPIED/FINISHED HIGH PERMEABLE SOILS	No	Waterproofing Fully Bonded to Concrete	Waterstops	Drainage Layer+ Gutter and Drains, Vapour Barrier and Mold Resistant Finishes	No	Waterproofing Fully Bonded to Concrete	Waterstops	Drainage Layer + Drain, Poly/ HPDE, Topping Slab and High Humidity Resistant Finishes

Key points to remember:

- Design the building so that the basic form, size, and features minimize uncontrolled cracking. If not sure, then introduce a control joint.
- Provide some overhang protection whenever possible especially where control joints are required.
- Provide two lines of defence in the water penetration control strategy for all construction and control joints.
- Provide two lines of defence for monolithic concrete areas (field portion) through the use of coatings in combination with the concrete itself.
- Place extruded polystyrene or spray-in-place urethane foam insulation against the interior surface of the concrete (in addition to any insulation placed in the stud space) to reduce potential for condensation and improve overall thermal performance.
- Window frames and other components that pass from the exterior to the interior should not be placed in intimate contact with the concrete (avoid thermal bridging).
- Continuity of critical barriers (thermal, moisture and air tightness in particular) should be maintained at all interfaces and penetration details.

- Confirm water penetration resistance of walls by testing of the wall assembly prior to closing in from the interior.
- All non-vertical concrete surfaces should be protected with waterproofing or metal flashing.
- Membranes should terminate on a vertical surface and the top edge should be protected.
- Waterproofing details at curbs should be designed and constructed using details that allow maintenance and repair of the membrane system without the requirement for concrete removal.
- Control surface runoff with drip edges and cants.
- Have heat, air and moisture control functions for the poured-in-place concrete elements reviewed at the design and construction stages by a qualified consultant with appropriate experience and professional qualifications. Include provisions for coatings and sealants in maintenance and renewal plans.

Information: For More Information:

“Study of Poured-in-place Concrete Wall Performance in Coastal British Columbia”, Canada Mortgage and Housing Corporation, Homeowner Protection Office, 2005. Available at www.cmhc.ca or www.hpo.bc.ca.

ACI 209R, “Prediction of Creep, Shrinkage and Temperature Effects in Concrete Structures”, Manual of Concrete Practice, American Concrete Institute, Detroit, MI, 2003. Available at www.aci-int.org.

CSA-A23.1-00, “Concrete Materials and Methods of Construction”, Canadian Standards Association, Toronto, 2000. Available at www.csa-international.org.

ACI 224R, “Control of Cracking in Concrete Structures”, Manual of Concrete Practice, American Concrete Institute, Detroit, MI 2003. Available at www.aci-int.org.

Cement Association of Canada, www.cement.ca.

Note: These weblinks are provided as a reference only and the Homeowner Protection Office (HPO), a branch of BC Housing, does not control or necessarily approve of any specific content of these websites.



For HPO Technical Research and Education inquiries, contact:
HPO Technical Research & Education

1701 – 4555 Kingsway
Burnaby, BC V5H 4V8
Tel: 778 452 6454
Toll-free: 1 866 465 6873

www.hpo.bc.ca
www.bchousing.org
Email: hpo@hpo.bc.ca

This bulletin contains excerpts as noted from the “Study of Poured-in-place Concrete Wall Assemblies in Coastal British Columbia”, 2005, the copyright for which remains with CMHC. All rights reserved. Reproduced with the consent of CMHC. All other uses and reproductions of this material are expressly prohibited. The views expressed in the study are the personal views of the author(s) and neither CMHC nor BC Housing accepts responsibility for them.

The information in this bulletin has been provided as general information only. The greatest care has been taken to confirm the accuracy of the information contained therein. However, the authors, funders and publisher assume no liability for any damage, injury or expense that may be incurred or suffered as a result of the use of this publication. The views expressed herein do not necessarily represent those of any individual contributor or BC Housing. It is always advisable to seek specific information on the use of products, the requirements of good construction practices and requirements of the applicable building code from manufacturers or suppliers of products and consultants with appropriate qualifications and experience. Please review and refer to the specific requirements of the building code for each construction project.